

## 6. ROUND COLUMN CLADDING

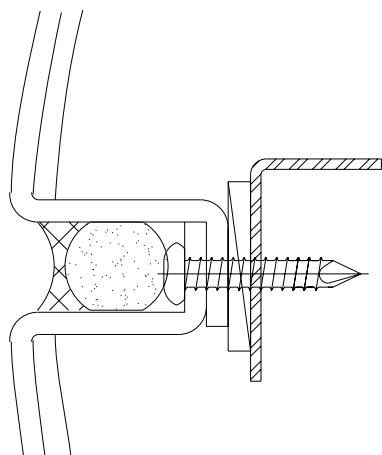

7. VERTICAL JOINT

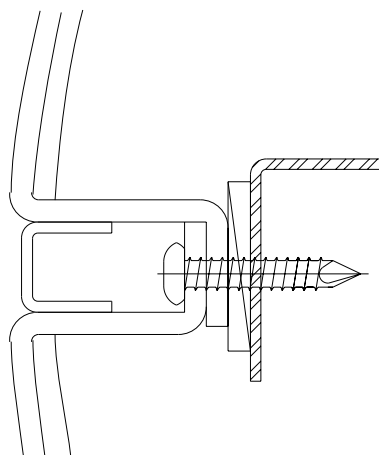

7A. ALTERNATE JOINT

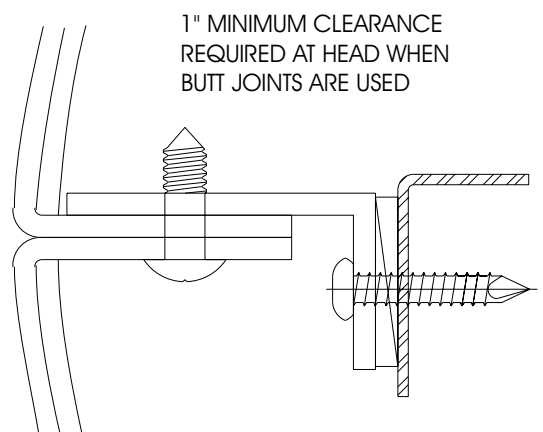

8. ALTERNATE BUTT JOINT