

TECHNICAL DATA SHEET

KANALCO LTD.
ARCHITECTURAL METAL PRODUCTS

REYNOBOND®
ALUMINUM
COMPOSITE
BUILDING PANELS

07430
JULY 1999
Composite Metal Building Panels
KANALCO LTD.



PRODUCT DESCRIPTION

Kanalco Reynobond® aluminum composite material consists of a thermoplastic compound core laminated between two 0.50 mm (.020") sheets of aluminum. The finished panel provides the rigidity and strength of composite construction with excellent architectural flatness for creating smooth, monolithic surfaces, exceptional load-bearing capacity and flexural strength – all with the virtual elimination of dimpling, buckling and oil canning.

Panel thickness ranges from 3 mm to 6 mm (1/8" to 1/4") and is also available with a proprietary fire-resistant (FR) core material.

Finishes

Reynobond Aluminum Composite Material is protected and colored with high-performance Colorweld 300 coatings. These finishes feature 70% KYNAR 500®/HYLAR 5000® polyvinylidene fluoride (PVDF) resins, coil coated to ensure the highest color uniformity and quality. Colorweld 300 coatings exhibit outstanding color and gloss retention, and are considered the premier architectural coating for metal. They provide excellent flexibility and film adhesion for forming, and offer superior resistance to humidity, impact, salt spray, pollution, abrasion and graffiti.

Opaque Finishes: These are 2-coat finishes typically consisting of a 0.2 mil primer and a 0.8 mil color coat, for a nominal dry film thickness of 1.0 mil.

Mica Finishes: These are 2-coat finishes typically consisting of a 0.2 mil primer and a 0.8 mil color coat with mica flakes suspended in the finish. Nominal dry film thickness is 1.0 mil.

Metallic Finishes: These are 3-coat finishes typically consisting of a 0.2 mil barrier primer, a 0.8 mil color coat and a 0.5 mil clear top coat, for a nominal dry film thickness of 1.5 mils.

Colors

Reynobond is available in 12 standard architectural colors:

Series 1: Frisco White (01), Classic Bronze (02), Parchment (03), Pueblo Tan (04), Oyster White (06), Cadet Gray (07), Pure White (16), Banner Red* (17), Konig Blue (18).

Series 2:* Platinum (21), Bright Silver Metallic (22), Champagne Metallic (23).

*Banner Red and Series 2 colors are premium colors comprised of mica or metallic finishes, available at a moderate upcharge.

Custom Colors or Finishes

Virtually any color can be produced in 2-coat, 3-coat (XL), metallic or mica finish-

es. Other coatings are also available to meet special requirements. Minimum quantities may apply. Set-up charges apply for less than 20,000 square feet (1858 square metres). Consult Kanalco for specific details.

USES

- Exterior or interior cladding
- Industrial and specialty product design. Example uses include:

- beam wraps
- interior walls
- elevators
- signage
- column covers
- ceilings
- partitions
- clean rooms
- canopies
- equipment covers

FEATURES

Strong; rigidity and strength provides extreme architectural flatness with virtual elimination of dimpling, bucking and oil canning, and exceptional load-bearing capacity and flexural strength.

Light; high strength-to-weight ratio allows cladding with little or no alterations to existing structural systems.

Formable; options include small radius curves, reverse curves, angles and radiused corners. Fabrication techniques include routing, drilling, punching, shearing, brake-forming, roll-forming, cutting, hot-air welding, bolting and riveting.

Easy Fabrication; shop forming using common woodworking and metalworking tools allows fabrication to exact specifications at relatively low cost.

Beautiful; ideal medium for imaginative and discriminating architects, builders, designers, engineers, and owners. Blends beautifully with other materials.

Versatile; in addition to an exterior building material, Reynobond can be used for a myriad of other applications. See "Uses". Reynobond is also more effective than solid metal panels in sound damping and vibration control. A variety of paint systems is available for specific applications.

Safe; available with fire resistant (FR) core that meets or exceeds national model building code requirements.

Durable; Colorweld® 300 coil coated panels are weather and corrosion resistant; Kynar 500® polyvinylidene fluoride coatings provide excellent chalk and fade resistance, humidity resistance, gloss retention, hardness, and flexibility. Lasting beauty and physical bond integrity in both outdoor and indoor environments are Reynobond attributes.

PANEL SIZES

Panel	Thickness	Standard Widths	Standard Lengths	Weight
RB120PE	3 mm (0.118")	1000 mm (39.37") 1220 mm (48") 1524 mm (60")	1220 mm (4'-0") to 4978 mm (16'-4")	4.59 kg/m ² (0.94 psf)
RB160PE	4 mm (0.157")	1067 mm (42") 1250 mm (49.2") 1270 mm (50") 1575 mm (62")	same	5.47 kg/m ² (1.12 psf)
RB200PE	5 mm (0.197")	same	same	6.44 kg/m ² (1.32 psf)
RB240PE	6 mm (0.237")	same	same	7.37 kg/m ² (1.51 psf)
RB160FR (.020" skins)	4 mm (0.157")	same	same	7.96 kg/m ² (1.63 psf)
RB200FR (.028" skins)	5 mm (0.197")	consult for availability	same	9.86 kg/m ² (2.02 psf)

TECHNICAL DATA

Surface Burning Characteristics (ASTM E-84): Class A

Product	Flame Spread	Smoke Developed
Reynobond PE	15	120
Reynobond FR	10	0
FR Core only	15	30

Toxicity: FR material is no more toxic than wood (evaluated by University of Pittsburgh, test method to New York Code Provisions). See Building Codes.

Paint Finish Performance

Property	Test Method	Opaque	Mica	Metallic
Specular Gloss 60%	ASTM D523-89	20-30	20-30	25-35
Pencil Hardness	ASTM D3363-92A	HB-H	HB-H	HB-H
Formability (T-Bend)	ASTM D4145-90	1T-No Cracking	1T-No Cracking	0T-No Cracking
Reverse Impact	ASTM D2794-93	No Cracking or Adhesion Loss	No Cracking or Adhesion Loss	No Cracking or Adhesion Loss
Abrasion Resistance - Falling Sand	ASTM D968-93	50 - 80 Litres	50 - 80 Litres	Minimum 130 Litres
Salt Spray Resistance (5% Salt Fog @ 95° F)	ASTM B117-95	Passes 3000 Hours	Passes 3000 Hours	Passes 3000 Hours
Humidity Resistance (100% RH @ 95° F)	ASTM D2247-94	Passes 3000 Hours	Passes 3000 Hours	Passes 3000 Hours
Atlas Weatherometer	ASTM D822-89	Passes 5000 Hours	Passes 5000 Hours	Passes 5000 Hours
Color Retention	ASTM D2244-89	Max 5 Units Change	Max 5 Units Change	Max 5 Units Change
Chalk Resistance	ASTM 4214-89	Max Rating of 8	Max Rating of 8	Max Rating of 8

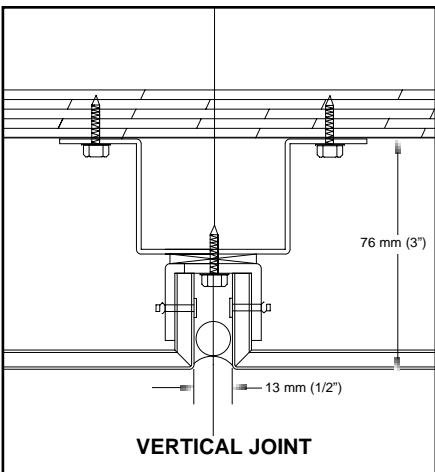
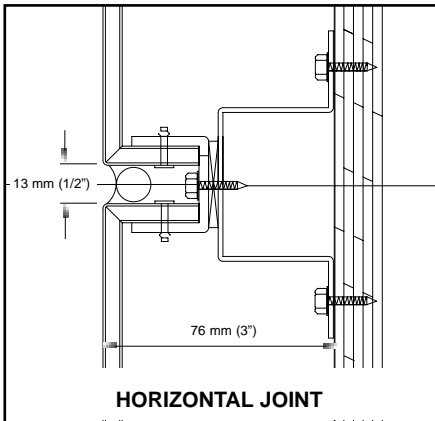

INSTALLATION

Reynobond panels can be installed using a variety of different methods i.e. rout and return (wet seal or dry joint) and continuous edge grip, or glazed into storefront or window applications.

Kanalco Ltd. are a custom manufacturer specializing in the metal fabrications field. Installation of the Reynobond composite panels is normally carried out by the appropriate trades and experienced installers according to specifications and approved shop drawings.

Building Codes: Reynobond is recognized as a cladding material for the following building codes:

- NBCC (National Building Code of Canada) and the various provincial codes.
- ICBO (No. PFC-4909, PFC-5051)
- BOCA (No. 93-57)
- SBCCI (PST & ESI No. 9509)
- New York City M.E.A. (No. 7591-M)
- Los Angeles (No. RR25121, RR25285)
- State of Wisconsin (Approval No. 930066-1)
- Chicago

Recognized internationally in the U.S., Canada, United Kingdom, France, Germany, Singapore, New Zealand, Australia, Hong Kong, Israel, Poland, and People's Republic of China.

RELATED DATA

- Reynobond "Material + Mind = Idea" architectural brochure.
- Reynobond Aluminum Composite Material Color Guide.
- Other Reynobond promotional literature.
- Other Kanalco technical literature e.g. Aluminum Wall Panels, Stainless Steel Wall Panels, Metal Column Covers, Rainscreen Cladding, and Pre-formed Metal Profiles.

MAINTENANCE

To keep aluminum composite building panels attractive, a definite maintenance program must be followed. The frequency of cleaning will depend on:

- atmospheric environment and severity of pollution.
- effect of weathering on the aluminum finish and ability of the finish to shed dirt and grime.
- cost involved.
- owner's interest in retaining the original appearance.

AVAILABILITY & COST

Reynobond is available worldwide. Contact Kanalco for information.

WARRANTY

Normal 1 year construction warranty.

TECHNICAL SERVICES

Kanalco Ltd. can provide consultation from preliminary design through to product application, including the following:

- technical advice for both new work and retrofit applications
- finish samples
- specification assistance
- shop drawings
- recommending contractor sources
- site advice and recommendations

SPECIFICATION

SPEC NOTE: This specification is basic and must be adapted to suit the requirements of individual projects. It is written in accordance with the CSC/CSI 3-Part Section Format. Square brackets [] indicate choice, alternatives, data required or need for the specifier to make a decision.

1 General

1.1 GENERAL REQUIREMENTS

- .1 Comply with General Conditions of Contract, Supplementary Conditions and the requirements of Division 1.

1.2 RELATED SECTIONS

- .1 Structural steel supports
Section [05100]
- .2 Cold formed metal framing
Section [05400]
- .3 Air/Vapor barrier
Section [07270]
- .4 Roof and Fascia Flashing
Section [07500]
- .5 Sealing between metal and [concrete] [masonry]
Section [07900]
- .6 Metal doors and frames
Section [08100]
- .7 Windows
Section [08500]

1.3 DESIGN REQUIREMENTS

SPEC NOTE: for 1.3.1 insert expected temperature range for locality of building including allowance for skin temperature heat gain in sunlight on colored finish.

- .1 Design cladding system to provide for thermal movement of component materials caused by ambient temperature range of [_____ °C (°F)] without causing buckling, wind rattle, undue stress on fasteners or other detrimental effects.
- .2 Include expansion joints to accommodate movement in wall system and between wall system and building structure, caused by structural movements, without permanent distortion.

- .3 Design framing members to withstand dead load and wind loads as calculated in accordance with NBCC and applicable municipal regulations, to maximum allowable deflection of L/175 of span or 19 mm (3/4") whichever is less for system supports, and L/60 of span for panel system.

- .4 Provide for positive drainage of condensation occurring within wall construction and water entering at joints, to exterior face of wall in accordance with [NRC "Rain Screen Principles"].

- .5 Design wall system to accommodate specified erection tolerances of structure.

- .6 Maintain following installation tolerances:

- .1 Maximum variation from plane or location shown on approved shop drawings: 1/2" in 20'-0" (13 mm in 6 m) maximum.
- .2 Maximum offset from true alignment between two adjacent members abutting end to end, in line: 0.75 mm (1/32").

1.4 SHOP DRAWINGS

- .1 Submit shop drawings in accordance with Section [01340].
- .2 Indicate dimensions, wall openings, head, jamb, sill and mullion details, materials and finish, anchor details, compliance with design criteria and requirements of related work.
- .3 Shop drawings complete with calculations to be reviewed by and bear stamp of a professional engineer.

1.5 SAMPLES

- .1 Submit duplicate 75 mm x 125 mm (3" x 5") samples of wall system, representative of materials, finishes and colors, in accordance with Section [01340] for approval.

1.6 QUALITY ASSURANCE

- .1 Qualification of Installer
Installation of cladding system to be by work forces approved by cladding fabricator as per written installation instructions provided by manufacturer.

1.7 MOCK-UPS

- .1 Provide mock-up on building consisting of complete cladding system, including but not limited to metal framing, panels, securement devices and mouldings for approval. Cladding finish and mouldings to be of finish and color as designated by the [Consultant] [Architect].
- .2 Location of mock-up to be as directed by [Consultant] [Architect]. Size to be four panels minimum in a 2 over 2 configuration.

.3 Modify mock-up as necessary for [Consultant's] [Architect's] approval. Mock-up [may] [may not] remain in place as part of completed work. Mock-up to represent standard for completed work.

1.8 STORAGE AND PROTECTION

.1 Handle, store and protect materials in accordance with cladding manufacturer's written instructions.

1.9 MAINTENANCE DATA

.1 Provide maintenance data for care and/or panel replacement for incorporation into operation and maintenance manual specified in Section [01730].

2 Products

SPEC NOTE: If more than one type panel, thickness, size, or color is required, specify type, etc. and ensure drawings or specifications indicate location of each type.

2.1 MATERIALS

.1 Composite metal building panels: Reynobond by Kanalco aluminum composite material consisting of a thermoplastic compound [PE] [FR] core laminated between two 0.50 mm (.020") sheets of 3105 H25 alloy aluminum; with Class 'A' Surface Burning Characteristics (ASTM E84); [RB _____] grade; [_____] thickness; [_____] color; [_____] panel size; as manufactured by Reynolds Metals Company and fabricated and furnished by Kanalco Ltd.

.2 Panel finish: Colorweld 300 coating consisting of 70% Kynar 500/Hylar 5000 polyvinylidene fluoride (PVDF) resins, coil coated to ensure highest color uniformity and quality, of color as specified, and thickness and paint finish performance as stated in manufacturer's literature.

.3 Copings and flashings: formed material to match cladding.

.4 Sub-girts: 1.2 mm (18 ga.) zinc coated steel to ASTM A525 with Grade A coating to ASTM Z275.

.5 Fasteners: all exposed rivets/ fasteners to be stainless steel; all concealed fasteners to be Climaseal coated or stainless steel.

.6 Sealants: compatible with panel material, in accordance with Section [07900], paragraph [_____], [_____ type] [_____ color] as selected by [Consultant] [Architect].

2.2 FABRICATION

.1 Panels to be factory fabricated in accordance with specifications and approved shop drawings.

.2 Bond panels using continuous process without using applied glues or adhesives.

.3 Maximum allowable fabrication tolerances to be:

- .1 Panel bow: 0.8% of panel dimensions.
- .2 Width or length ± 0.80 mm (0.032") up to 1200 mm (48") ± 1.5 mm (0.064") from 1220 mm to 3360 mm (48" x 144").
- .3 Squareness: Maximum 4.7 mm (0.187") difference between diagonal measurements.

.4 Form all panels to specified dimensions with tolerances to accommodate thermal expansion and contraction between panels and structural members. Accurately form radii of curved panels in plant.

.5 Factory fabricate accessory and trim components, ready for installation.

.6 Ensure panel surfaces are free of fabrication scratches or marks, and that entire project is manufactured from single color coil paint run to ensure color uniformity.

.7 For metallic colored panels, ensure panel grain is maintained, with no panel blank sizes rotated.



3 Execution

3.1 INSPECTION

.1 Prior to installation, examine alignment of substrate and notify [Consultant] [Architect] in writing if substrate does not comply with manufacturer's recommendations.

3.2 INSTALLATION

.1 Install claddings in accordance with manufacturer's written instructions and shop drawings. Allow for thermal movement.

.2 Maintain following installation tolerances:

- .1 Maximum variation from plane or location shown on shop drawings: 10 mm/10 m (3/8" in 30'-0") of length and up to 20 mm/100 m (3/4" in 300'-0") maximum.
- .2 Maximum deviation for a vertical member: 3 mm (1/8") in a 8.5 m (25'-0") run.
- .3 Maximum deviation for horizontal member: 3 mm (1/8") in a 8.5 m (25'-0") run.
- .4 Maximum offset from true alignment between two adjacent members abutting end to end, in line: 0.75 mm (1/32").

.3 Brake form metal flashings to profile required, in maximum lengths.

.4 Where aluminum materials come in contact with dissimilar materials, install isolation shim or tape at fastening locations.

.5 Install head and sill flashings, edge trim, cap pieces, and other metal profiles as applicable and/or detailed.

.6 Obtain panel symmetry whenever possible relative to openings in both vertical and horizontal plane.

.7 Employ [control] [expansion] joints as indicated.

.8 Remove excess sealant using recommended solvent.

.9 Remove strippable coating from panels as cladding is installed.

.10 Ensure dry joint panel system has no exposed sealant in panel joint.

3.3 CLEANING

.1 As work progresses, remove any excess or foreign materials which would set up or become difficult to remove from finished surfaces.

End of Section

KANALCO LTD.

ARCHITECTURAL METAL PRODUCTS

345 Lake Road, Bowmanville, Ontario, Canada L1C 4P8

1-800-268-8139 Fax: 888-779-9914 e-mail:

sales@kanalco.com www.kanalco.com